

Optimeret stribefundament

v. Tim Gudmand-Høyer og Julie Corneliusen

RAMBOLL

Bright ideas.
Sustainable change.

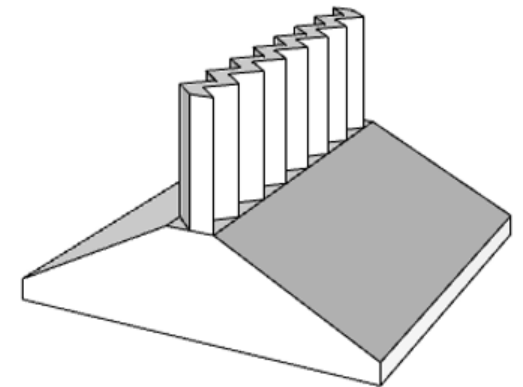
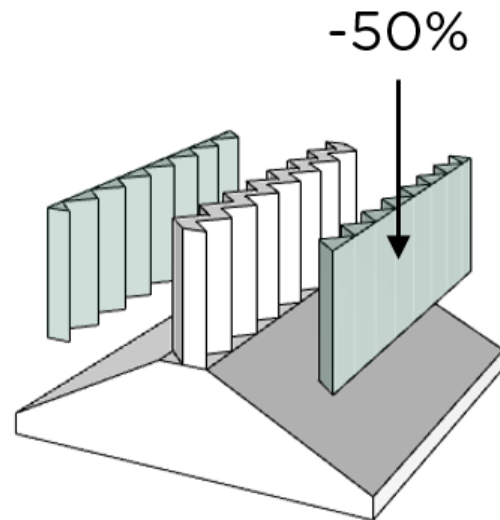
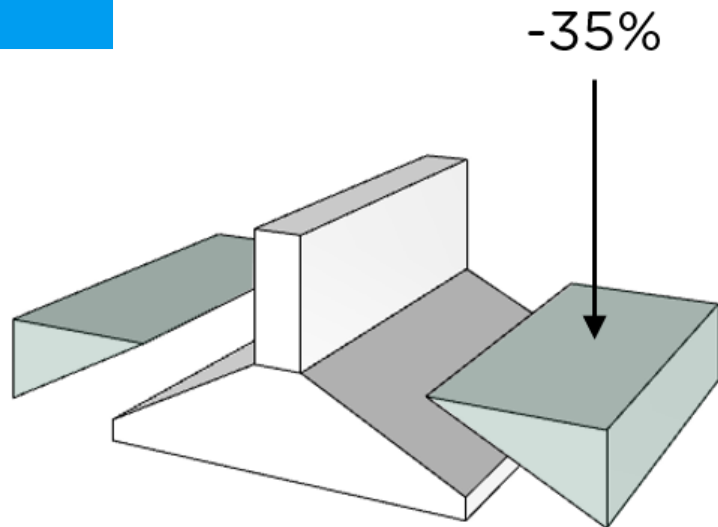
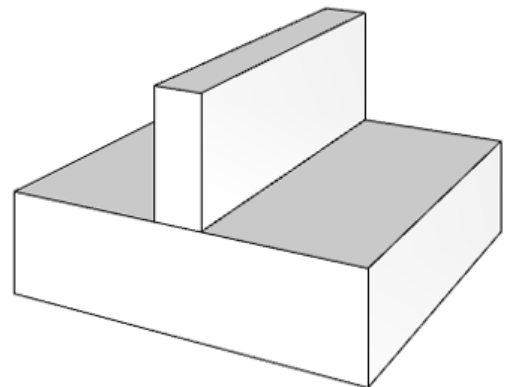

Agenda

1. Om initiativet
2. Samarbejdet og processen
3. Armeringsdesign
4. Selvkompakterende beton
5. Støbeform
6. CO2-besparelser
7. Praktiske erfaringer
8. Mere inspiration...

Om initiativet

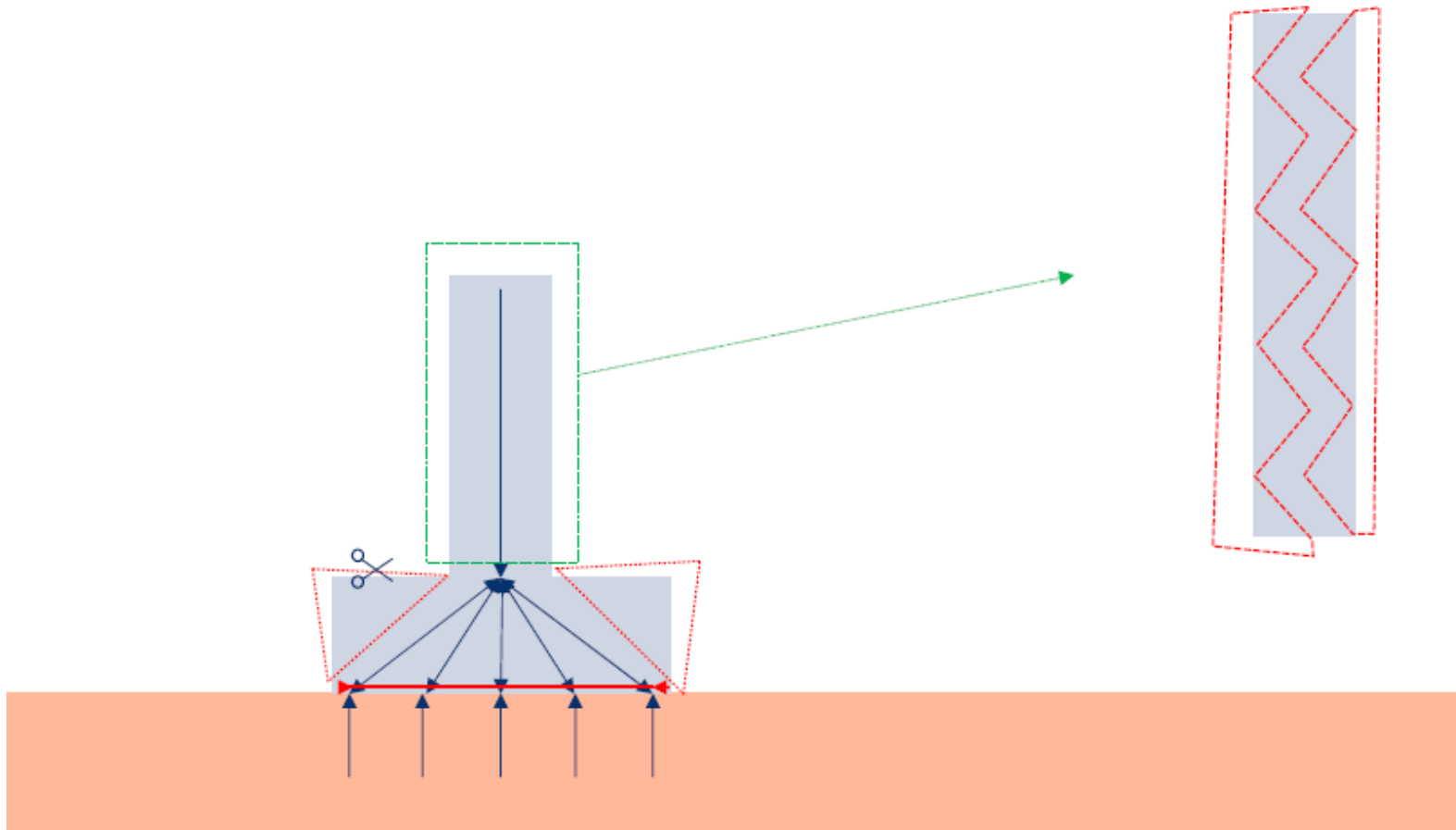

- Fordi vi kan trimme noget væk
- Lad os undersøge bygbarheden
- Vi vil gerne lære noget af det

- Hvad er udfordringerne?
- Er det skalerbart?

- Hvem vil lege med?
- Lege-regler: Der er ingen penge, man leger med for egen regning

Samarbejdet og processen

Tidsramme: December + januar

Legekammerater: Lemvigh-Müller

Unicon

PERI Denmark

Odico

NCC

PEIKKO

Rambøll

NREP



Armeringsdesign

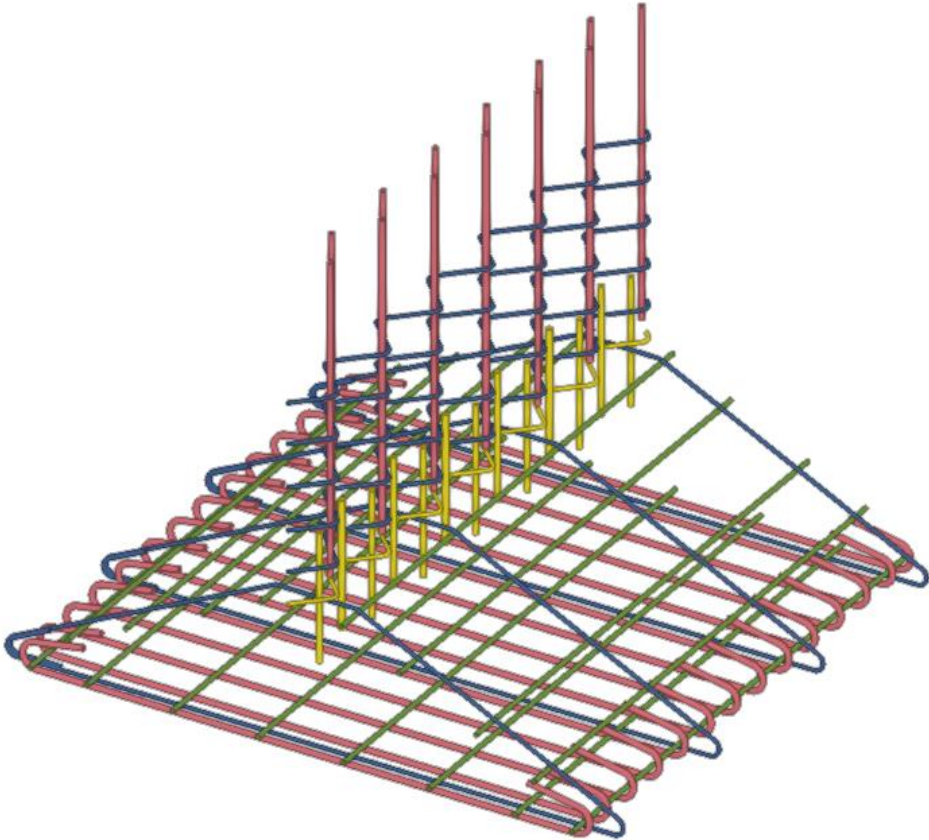

Selvkompakterende beton



Sætmålsbeton:

M30 med RAPID cement = 290 kg

M30 med FUTURECEM = 220 kg



Selvkompakterende beton:

M30 med RAPID cement = 310 kg

M30 med FUTURECEM = 235 kg



Sammenligning:

CO₂-besparelse v. sætmålsbeton

... men arbejdsmiljø må indtænkes

Støbeform



Støbeform

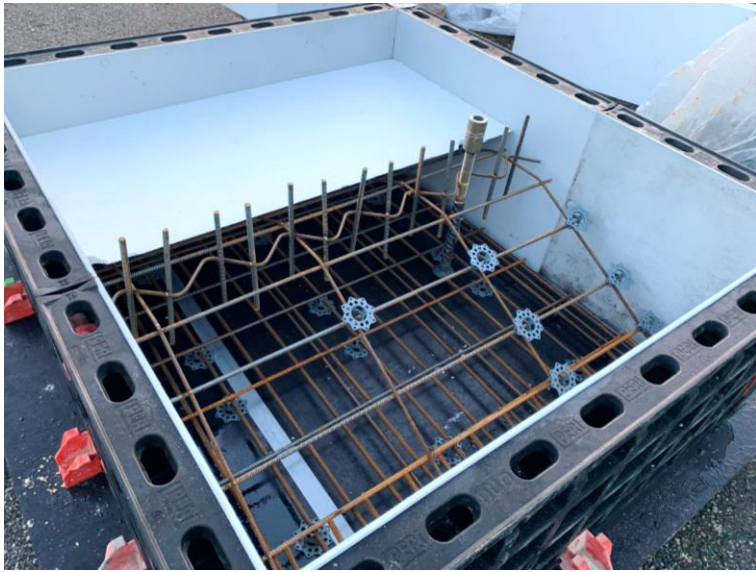

CO2-besparelser

Forudsætninger:

- Baseret på håndberegninger
- A1-A3 for anvendte produkter
- Holdt op mod generisk data

Resultater:

- Besparelse i volumen: -34%
- Besparelse i materiale: -17%
- Besparelse i alt: **-46%**

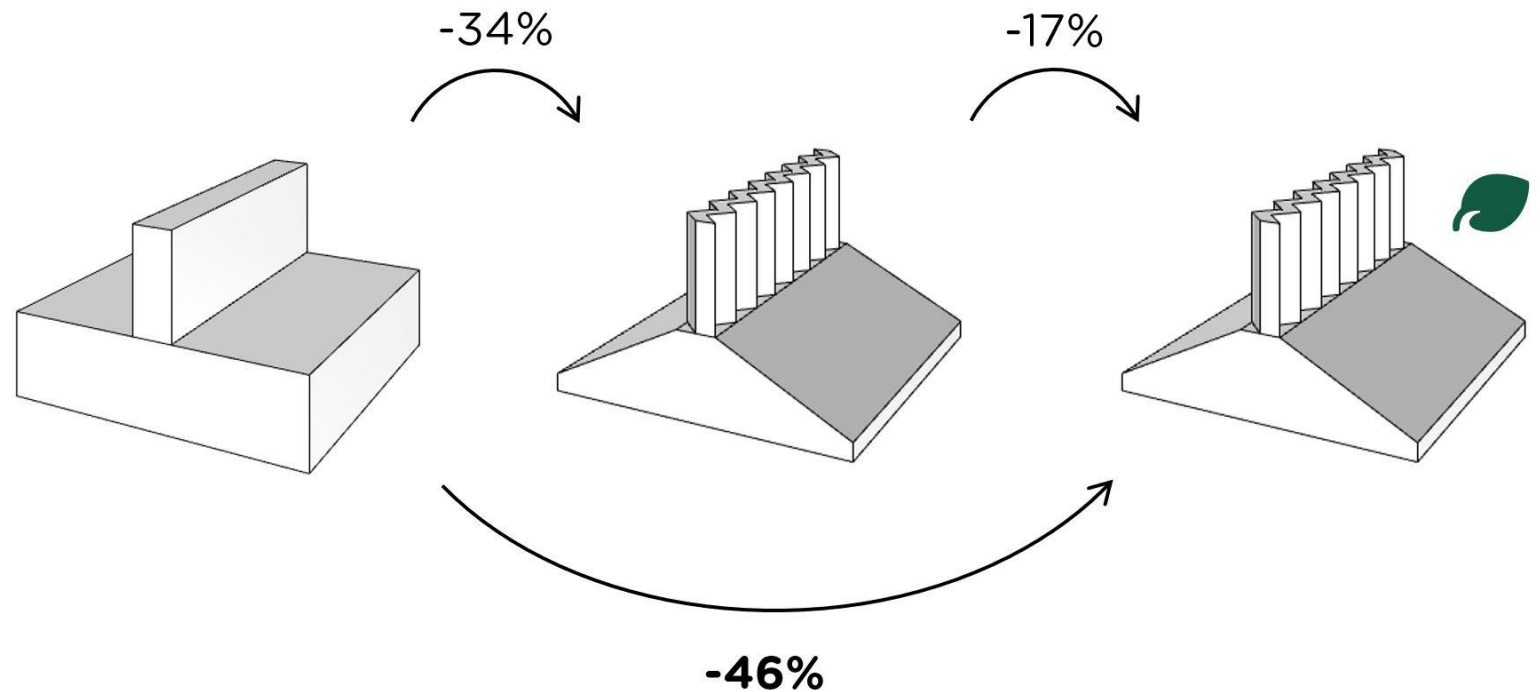

Praktiske erfaringer

- Proof-of-concept
- Udfordringer i skaft: Skala og tolerancer
- Svage punkter på EPS-formen
- "Stjerner" som afstandsklodser



Mere inspiration...

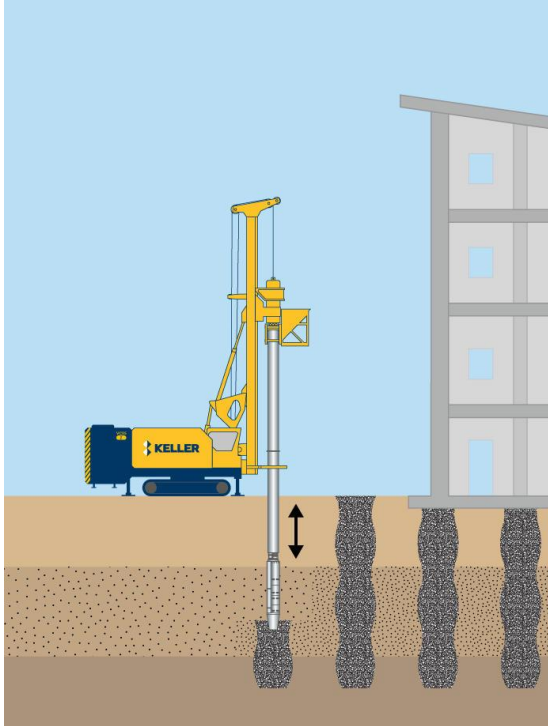

Vibrerede stenpæle



Hule pæle af Aarsleff

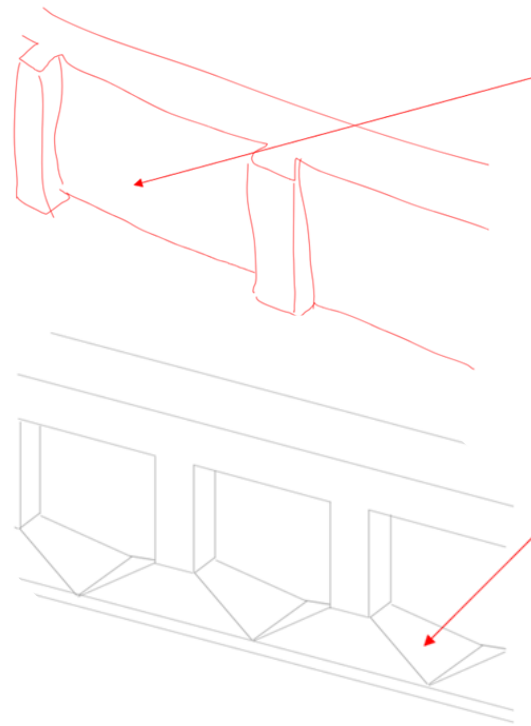

Idéer til sandkasseforsøg

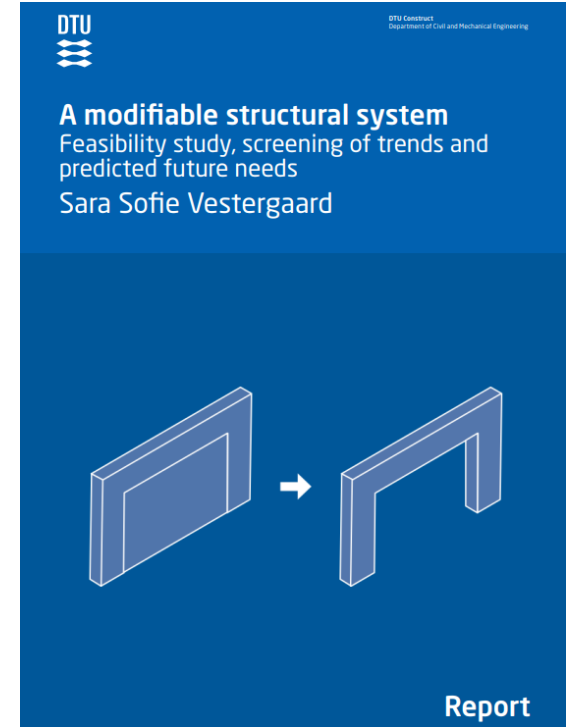

Ph.d. projekt i Rambøll